

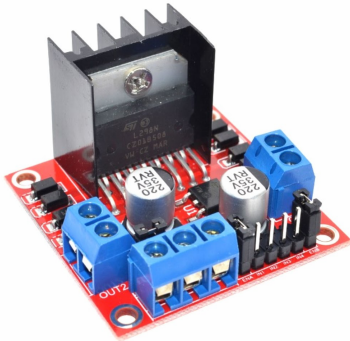

Dual H Bridge L298N DC Stepper Motor PWM Drive Controller



This L298N-based driver module is a high voltage, high current dual full-bridge driver designed to accept standard TTL logic levels and drive inductive loads such as relays, solenoids, DC and stepping motors from 5V to 35V. It can easily control the DC motor speed and direction, and can also control 2-phase stepper motors. It can be used for other projects such as driving the brightness of certain lighting projects such as high powered LED arrays using Pulse Width Modulation (PWM) control.

Two enable inputs are provided to enable or disable the device independently of the input signals.

The motor direction is controlled by sending a HIGH or LOW signal to the drive for each motor (or channel). For example for motor A, a HIGH to IN1 and a LOW to IN2 will cause it to turn in one direction, and a LOW and HIGH will cause it to turn in the other direction.

The module includes an onboard 5V regulator. When enabled by the jumper, the 5V is provided as an output on the power connector, and can be used as a 5V DC supply for your other circuit components. (When enabled, the module input voltage must be at least 6V). When disabled, a separate 5V input provides in order to control the logic level circuitry of this module.

Controller Parameters:

- Driver chip: L298N dual H-bridge driver
- Drive Voltage: +5V to +35V (Input voltage must be at least 6V when internal 5V regulator is enabled)
- Drive peak current I_o : 2A / Bridge
- Logic power supply range V_{ss} : +4V to +5.5V DC (Not required when internal regulator is enabled. When enabled, the 5V is available as an output on the power connector)
- Control signal input voltage range: 4.5-5.5V high 0V low
- Maximum power consumption: 20W
- Storage temperature: -25 ~ +130 C
- Dimensions (approx): 43mm x 43mm x 27mm LxWxH (1.7" x 1.7" x 1.1")
- Weight: 26g

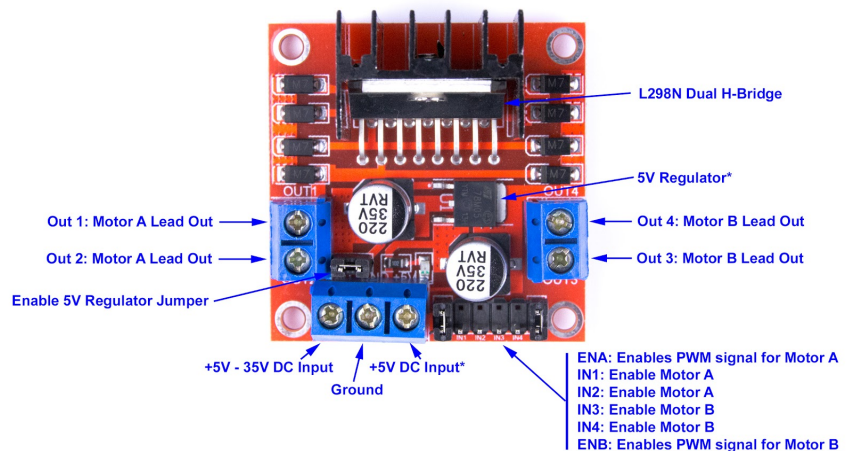

* +5V Input if onboard regulator is disabled, or +5V Output if regulator is enabled

Other References:

Youtube: HOW TO video: <https://www.youtube.com/watch?v=kv-9mxVaVzE>

Instructables: <http://www.instructables.com/id/How-to-use-the-L298-Motor-Driver-Module-Arduino-Tu/>

Copyright © 2017 Envistia Mall

www.envistiamall.com

P/N EM-MOTOR-0001